

FN485 Gateway 2 Galvanically Isolated V1.0



Figure 1. The FN Gateway

Overview

The FN Gateway is a DIN rail mountable hardware device (shown in Figure 1.) which has been developed to convert the master/slave FN-485 bus architecture into an event driven multi-master bus architecture. It is recommended for installations where prompt status information of FN485 module inputs and outputs is required.

Main Features

- Converts the master-slave architecture of the RS-485 bus into an event driven system
- 60 memory positions for programming queries
- Free PC software to program/retrieve queries
- Galvanically isolated RS-485 bus so that potentially harmful spikes and overvoltage occurring on the bus can't get to the main controller

The role of the FN Gateway

In a system with a central controller (master), the controller is usually required to be notified about the input/output status changes of the FN485 modules.

The FN485 bus is a master/slave bus where only the master can initiate requests and all the other bus modules (slaves) can only respond to these requests. Therefore, the status of the module inputs and outputs can only be retrieved by continuously polling the FN485 bus. Polling the bus means sending out status query commands to all the modules in rapid succession.

In real world installations the module input/output status changes are quite rare compared to the frequency of polling, therefore most of the responses will not hold any new information. Quick polling is still needed so that the system can react to input/output changes within an acceptable period of time. For instance, when a movement sensor senses motion, a light may need to switch on immediately without any delay. A slow to respond system can cause an annoying delay to a person waiting in the dark for the light to turn on.

The FN Gateway was developed to do the polling, taking the burden of quick polling off the controller.

Besides doing the polling, the FN Gateway is also able to route FN485 commands and responses to and from the FN485 bus modules. This means that from the point of view of FN485 instructions and queries the FN Gateway is transparent, i.e. used as a regular RS232/RS485 converter.

The FN Gateway may not be required in a system with a central controller of high processing power that enables quick polling and RS232/RS485 conversion.

In order to keep the response time low, it is not recommended to connect more than 20 FN485 modules to the same bus. However, you can have more than one bus in the same installation, each connected to the central controller via a different FN Gateway.

Connecting the FN Gateway

Figure 2. illustrates a simple FN configuration using the FN Gateway.

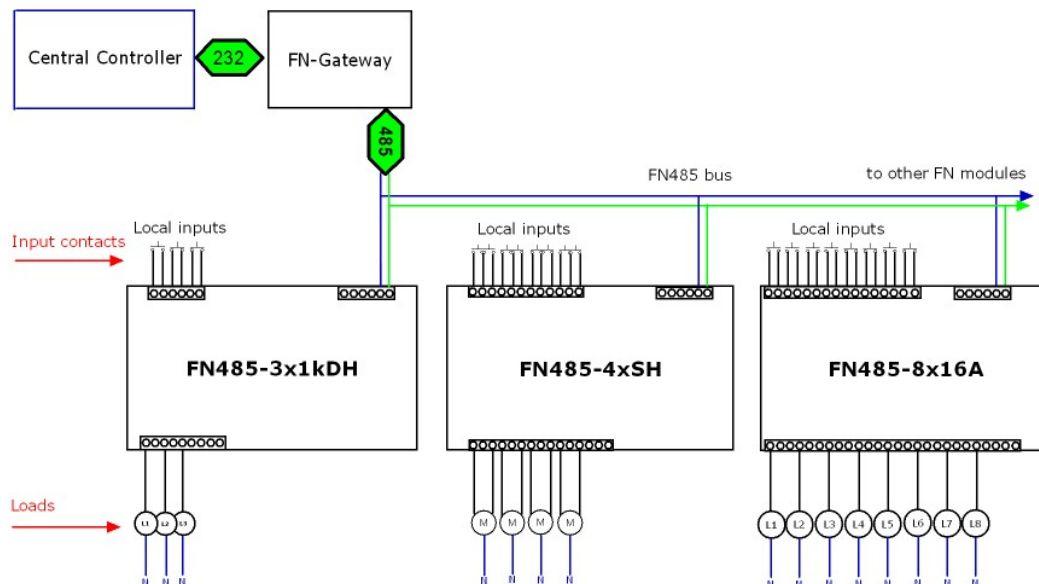

Figure 2. Connection diagram of an FN485 bus connected to a central controller via an FN Gateway

The FN Gateway's RS232 side is connected to one of the free RS232 ports of the controller. The RS485 side must be hooked up to the FN485 bus. The FN485 bus topology requires daisy-chaining the bus modules. In case the FN Gateway is placed somewhere else than at the end of the bus the jumper should be removed.

Figure 3. illustrates the terminal connections of the FN Gateway.

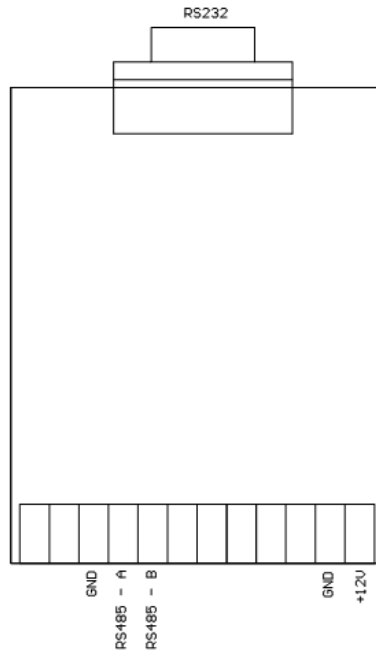

Figure 3. Terminal connections of the FN Gateway

Operation of the FN Gateway in details

The FN Gateway functions as the master of the connected FN485 bus and it keeps polling the slave FN485 modules based on a query list. The queries are editable by the software utility available upon request. The drivers/software modules written for main controllers such as Control4, AMX are able to program the query list into the Gateway automatically (based on the module types and parameters added to the project by the installer). Then it compares the responses from the modules with its database, which contains previously received data. If the status of the polled module has not changed or a timeout occurs, the FN Gateway will send the next query from the query list. If any monitored parameter of a polled module has changed, the FN Gateway will forward the full response to the controller via its RS232 port and will continue querying. This way only reports of changes will occur on the RS232 side.

The FN485 commands sent by the controller via the RS232 port always have priority over the queries of the FN Gateway. If no FN485 command arrives from the RS232 side then the FN Gateway will send the next query stored in its memory to the FN485 bus. It will only send the response to the RS232 port if it differs from the previously received response to the same query.

Technical Specifications

Power

12V DC, max. 150mA

RS232

RS232 D-Sub9 Female connector

Communication settings: 9600,N,8,1

RS485

Half duplex

Communication settings: 9600,N,8,1

Max. Bus Length: 1000m

Max. No. of modules on a bus: 32 (127 with special comm. chip)

Other parameters

Operating temperature: 0 C – 70 C (32-158 F)

Dimensions: W x H x D = 70 mm x 100 mm x 57 mm (4 DIN unit width)

Weight: 0.12 kg

Color: Light grey with black cover plate

Standards

EN 61000-6-1:2007

EN 61000-4-2:2009

EN 61000-4-3:2006/A1:2008

EN 61000-4-4:2005

EN 61000-4-6:2009

EN 55022:2007/A2:2007

EN 55022:2007/A1:2008

EN 55024:2000

RoHS

References

FutureNow FN485-8x16A Installation Manual
FutureNow FN485-3x1kDH Installation Manual
FutureNow FN485-4xSH Installation Manual
FutureNow FN485-4x0-10V Installation Manual
FutureNow Protocol Description
FN Gateway Query Editor Command Set
FN Gateway Query Editor Software Utility

Contact details

support@p5.hu